

HOW OSCILLOSCOPES WORK

BASIC ANALOG OSCILLOSCOPES

The circuitry of a simple analog oscilloscope can be broken into three blocks as shown in Fig. 11. These three blocks are the vertical circuitry, the horizontal/trigger circuitry, and the display circuitry. By understanding each of these blocks on its own, it will become much easier to understand how they interact and why the oscilloscope's controls function the way that they do.

Vertical Circuitry

Refer to Fig. 12.

The vertical circuitry controls the vertical axis of the display and consists of an input coupling circuit, the input attenuator, and the vertical amplifier (for dual trace oscilloscopes, there are two identical vertical circuits, one for each channel). All signals connected to the vertical input jacks are fed through at least part of the vertical circuitry before they are used by other oscilloscope circuits.

The Input Coupling Circuit

The input coupling circuit allows the user to ground the oscilloscope's input, pass only the ac portion of the signal, or pass both the ac and dc portions of the signal. When the input coupling circuit is set to ground the scope input, the attenuator input is grounded, but the input jack is open (to prevent a short circuit at the probe). This mode is useful for setting the trace to a zero reference level. When the input coupling switch is set to pass only the ac, the scope input jack is capacitively coupled and any dc signal component is blocked. When the input coupling switch is set to pass both the ac and dc signal components, the oscilloscope input jack is directly coupled to the attenuator and both the dc and ac (dynamic) portions of the signal are passed.

The Input Attenuator Circuit

The input attenuator allows a wide range of signal levels to be applied to the oscilloscope by setting the vertical sensitivity of each channel.

The basic sensitivity of an oscilloscope's vertical amplifier is typically 5 mV per division. Lower sensitivities, up to 5 volts per division, are achieved by attenuation of the input signal. Typically, input attenuator circuits are set up in a 1-2-5 sequence and allow measurements of signal levels from a few millivolts to tens of volts. In other words, input sensitivity might be

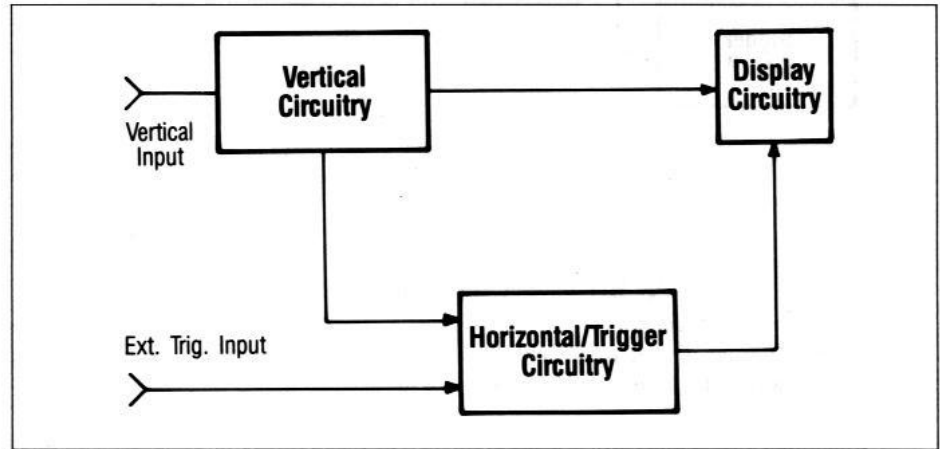

Fig. 11. Simplified oscilloscope block diagram.

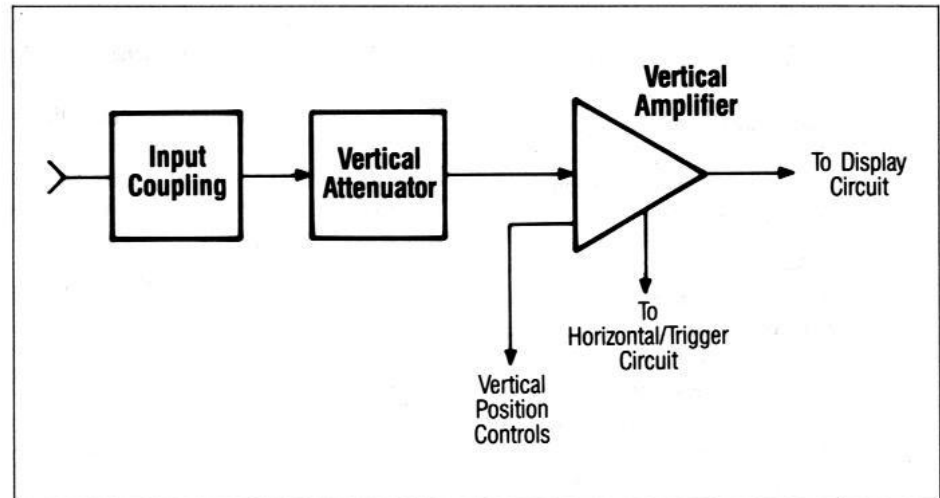

Fig. 12. Vertical circuitry block diagram.

switchable to 5 volts/div, 2 volts/div, 1 volt/div, 0.5 volts/div, etc.

In order to provide a calibrated voltage measurement on the display, vertical input attenuators must be highly accurate wideband networks, capable of passing all signals within the oscilloscope's measurement range (e.g. for a 20 MHz scope, these attenuators must provide a flat response for signals from dc all the way to 20 MHz).

In addition to the step attenuator controls, oscilloscopes also have a variable sensitivity control that allows the scope sensitivity to be set between step attenuator ranges. This control allows waveforms to be set to occupy an exact number of divisions, such as is necessary for

rise time measurements, where the waveform must extend exactly from the 0% to 100% markers.

For input sensitivities greater than 5 mV per division (for example, 1 mV per division), an additional amplifier is switched into the circuit instead of an attenuator. The bandwidth is typically reduced when the amplifier is selected.

The Vertical Amplifier Circuit

From the input attenuator, the signal is fed to the vertical amplifier, where it is amplified to a level suitable for driving the CRT vertical deflection plates. Depending on the display mode (single- or dual-trace, chopped, or alternate display), the vertical amplifier stage also handles the switching of signals to facilitate

HOW THE OSCILLOSCOPES WORK

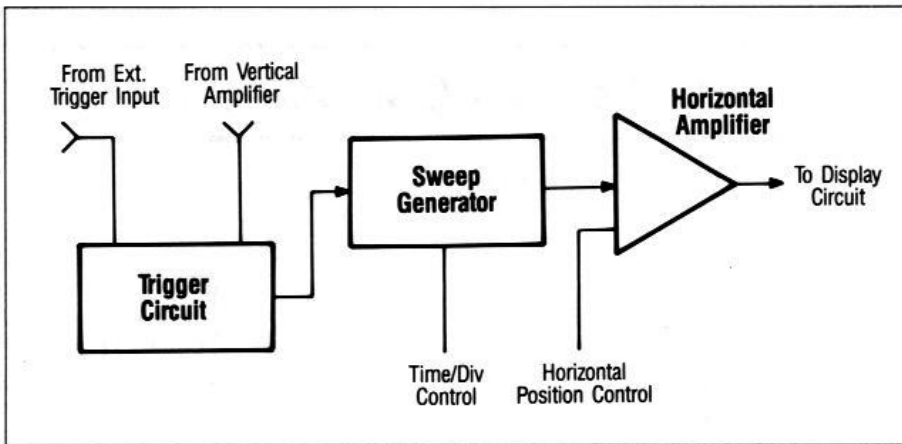

Fig. 13. Horizontal/trigger circuitry block diagram.

the display of channel 1, channel 2, dual-trace chopped, dual-trace alternate, etc.

Also, at a preamplifier stage, a portion of the signal is picked off and fed to the horizontal/trigger circuitry. Position controls adjust the dc bias of the amplifier circuit and allow the trace to be moved about vertically.

Horizontal/Trigger Circuitry

Refer to Fig. 13.

As suggested by its name, the horizontal/trigger circuitry controls the horizontal axis of the trace. The horizontal/trigger circuitry can be further broken down into three distinct sections: the trigger circuit, the sweep generator, and the horizontal amplifier.

The Trigger Circuitry

The oscilloscope's trigger circuitry plays the very important role of telling the scope's other circuitry when to start drawing the trace. Since the scope display provides a graph of voltage versus time, it is very important that the scope starts drawing at the same point on the waveform each time it sweeps across the display. If the oscilloscope could not precisely control the trigger point, it would be impossible to measure anything related to time. The sweep would start at a different point each time, and therefore, the waveform would be moving to a different position on the display each time the CRT was swept.

The trigger level and slope controls allow the scope user to select the exact point at which the sweep will be triggered. The slope control allows selection of either the positive- or negative-

going slope, and the level control allows the selection of the exact point on that slope. Fig. 14 illustrates the way that the slope and level controls function.

The trigger circuits also perform the switching that selects the trigger source. Since it is frequently desired to trigger from an event other than the signal that is being viewed, oscilloscopes allow a selectable trigger source. This source can be internal (one of the channels being displayed) or external (the signal applied to the external trigger input jack), or line frequency.

When an internal trigger source is selected, a portion of the signal from one or more of the vertical preamplifiers is fed to the trigger circuits. This signal can be the channel that is being viewed on the CRT, a channel that is not being viewed, or, in the case of multiple trace display, the trigger source can automatically switch between each of the channels as it is displayed.

This is known as alternate triggering and is used in conjunction with alternate display.

When an external trigger source is selected, the source is the signal that is applied to the external trigger input jack. Typically, external triggering is used for such things as viewing logic signals with reference to a known timing.

Line triggering uses the line frequency for triggering and is used for work on power supplies, or circuits that must be synchronized with line voltage.

Trigger coupling is also selected within the trigger circuitry. Typical trigger coupling modes are ac (trigger signal is capacitively coupled and all ac signal components are used), high frequency reject (trigger is capacitively coupled and a low-pass filter rejects all high-frequency signals), and low frequency reject (trigger signal is capacitively coupled and a high-pass filter rejects all low-frequency signals). The cutoff point for high and low pass filters varies between oscilloscope models and brands. Most scopes also have TV trigger coupling (using a sync separator) to trigger from horizontal or vertical TV sync pulses. This mode is useful for viewing frames (vertical sync pulses) or lines (horizontal sync pulses) of video signals.

The Sweep Generator (Time Base)

After the selected trigger event occurs, a linear sawtooth sweep generating circuit is turned on and produces the waveform shown in Fig. 15. The first part of the waveform is the linear sweep ramp that causes horizontal movement of the trace. As voltage is increased, the electron beam moves further to the right of the CRT. When the voltage reaches its peak level

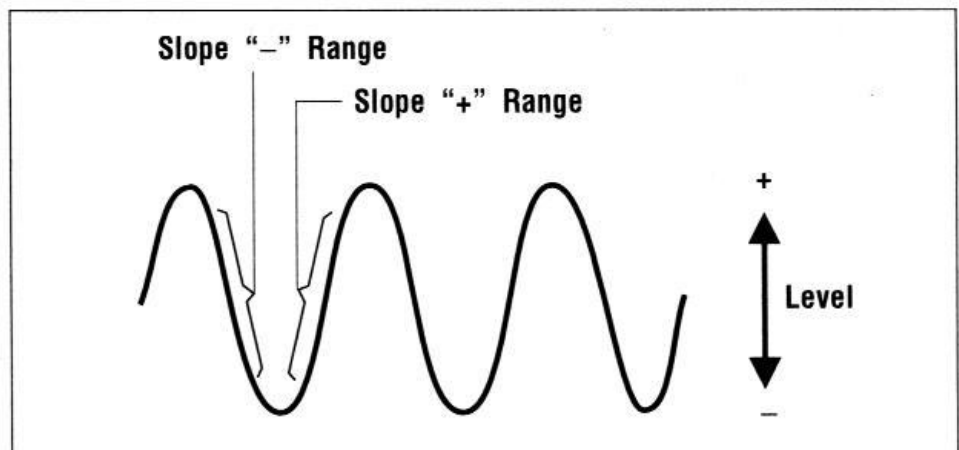

Fig. 14. Function of slope and level controls.

HOW THE OSCILLOSCOPES WORK

(the top of the ramp), the electron beam is at the right edge of the CRT. At this point, the electron beam is turned off (this is called retrace blanking) and the sweep voltage returns to the original level, thereby also returning the electron beam to the left side of the CRT.

The sweep ramp is typically generated by a circuit known as a Miller integrator. This circuit takes a dc voltage as its input and performs the mathematical process of integration on it. Integration of a dc level produces a linear ramp. Various combinations of resistance and capacitance are used to control the speed of the ramp, and hence, the sweep speed. When the ramp reaches a certain level, the dc voltage is removed from the input of the integrator, causing the ramp to reset. The dc input is sometimes provided by a flip-flop, and removal of the dc level simply involves applying a reset pulse to that flip-flop.

In Fig. 15, note the "holdoff" period that occurs immediately after the completion of each sweep. This is a period during which the next sweep is inhibited. Length of the holdoff period is controlled by the length of the reset pulse to the flip-flop mentioned above. The holdoff period varies with the sweep rate, but is adequate to assure complete retrace and stabilization before the next trigger occurs.

Since it is desirable to measure time on the horizontal axis, it is important that the sweep time (the time that it takes for the electron beam to move from the left edge to the right edge of the CRT) is linear (constant speed all the way across) and calibrated. The step time base control provides calibrated sweep times from seconds to micro- or nanoseconds. As with the step input attenuator, the time base control is usually arranged in a 1-2-5 pattern (0.1 S/div, 0.2 S/div, 0.5 S/div, 1.0 S/div, etc.). There is usually a variable time base control that allows for adjustment between step time base ranges (although use of this control causes the time base to become uncalibrated).

Most oscilloscopes also have a sweep magnification control that allows the entire trace to be magnified. For example, if the main step time base control is set to 0.5 mS/div and X10 magnification is selected, the actual time base becomes 0.05 mS/div (50 nS/div).

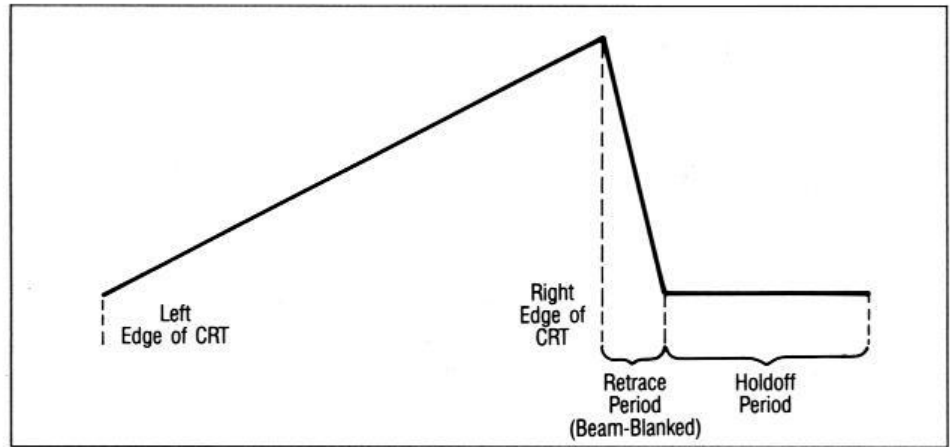

Fig. 15. Sweep waveform.

The Horizontal Amplifier

The horizontal amplifier simply boosts the signal to a level capable of driving the CRT's horizontal deflection plates. Since the sweep speeds can range from seconds to micro- or nanoseconds, this amplifier must have a relatively wideband width and must faithfully reproduce the linear sawtooth sweep waveform. Position controls adjust the amplifier's dc bias and allow the trace to be moved about horizontally.

The Display

The CRT

The CRT, or cathode-ray tube, is made of glass and contains a vacuum. Electrons are emitted from a heated element at the narrow end of the tube and are accelerated by a high voltage, typically 2000 volts or greater, towards the display end. On the way there, they are focused into a narrow beam whose direction is altered slightly by vertical and horizontal deflection

plates. These deflections are controlled by the outputs of the vertical and horizontal amplifiers mentioned previously. Therefore, the beam moves up and down in relation to the input signal, and horizontally in relation to the time base circuitry. The display end of the tube is coated by a monochrome phosphor, usually green, which glows where it is struck by the electrons.

The Graticule

The oscilloscope display represents a graph of voltage versus time. As seen in Fig. 16 the horizontal component of the graph represents time and the vertical component represents voltage. Typically, oscilloscope displays have a graph, or graticule, that is divided into 10 horizontal and eight vertical divisions. Each of these divisions is usually broken into 5 minor divisions (subdivisions), represented by the "hash" marks along the center vertical and horizontal graduations. Additionally, the graticule

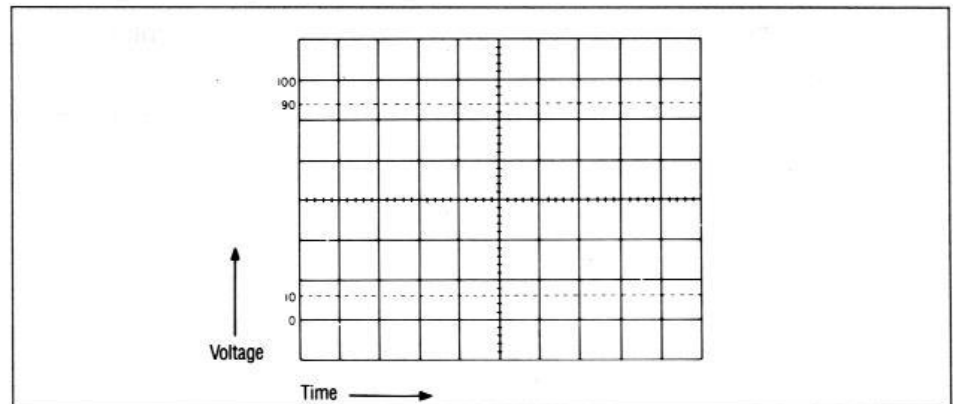

Fig. 16. Typical oscilloscope graticule

HOW THE OSCILLOSCOPES WORK

is marked with two dashed lines, labeled "10" and "90" and points marked "0" and "100" are also present. These four points are useful for rise time and fall time measurements, since rise time is defined as the time required for a signal to rise from 10% to 90% of its maximum amplitude. On almost all modern oscilloscopes, the graticule is etched directly onto the inside of the CRT. This eliminates parallax error that might occur from viewing the CRT from a slight angle.

ADVANCED ANALOG OSCILLOSCOPES

Delayed Sweep

Delayed sweep is a very important feature of many advanced scopes. It allows a portion of the trace to be magnified. The original trace is sometimes referred to as the A sweep, and the magnified trace as the B sweep.

Fig. 17 shows a block diagram of the delayed sweep circuit and a representation of the process. The trigger starts the A sweep generator and several cycles of the square wave input are displayed. The trigger is also applied through a variable delay network, the Delay Position control, which is adjustable by the operator. In the Mix sweep mode, the delayed trigger starts the B sweep generator at a later point in time. The delay is typically adjustable from one division to ten divisions on the screen. When the B sweep starts, the display is switched to view the faster B sweep for the balance of the trace. Since the B sweep is faster, that portion of the waveform is expanded.

When the Sweep Mode Switch is set to the Delay position, only the faster B sweep is viewed. The starting point of the waveform is still adjustable with the Delay Time control.

Variable Holdoff

As mentioned previously, all scopes have some degree of holdoff between CRT sweeps. This is necessary to provide time for the beam to return to the left edge of the screen. Many advanced units also provide a variable holdoff, which allows this interval to be lengthened by the user. This is useful for synchronizing on complex pulse trains.

As discussed in "Basic Analog Oscilloscopes" above, holdoff depends on the width of a reset pulse applied to the flip-flop, which drives the Miller integrator. Variable holdoff is achieved by varying the width of that reset pulse.

Other Features

Delay Line

Many high bandwidth oscilloscopes have a delay line in the vertical amplifier. This delay line actually slows the signal down (by a fraction of a microsecond) so that the oscilloscope can start the sweep before the vertical signal starts to deflect the CRT's electron beam. This allows the scope to display the signal, including the trigger edge. It is generally needed only in cases where the rise time (or fall time, if trigger occurs on a falling edge) of a very fast signal needs to be observed. That is why only high bandwidth scopes usually have delay lines; if the bandwidth of the scope is not high enough to view a very fast rise time, a delay line offers no advantage.

Higher CRT Voltages

A typical 20 MHz or 30 MHz oscilloscope has a CRT acceleration voltage of 2000 volts. Higher voltages deliver brighter traces and are essential for wideband scopes. As the time that it takes for the electron beam to sweep across the CRT is decreased (higher bandwidth scopes have higher maximum sweep rates), the voltage must be increased in order for the trace to still be easily visible. Some 100 MHz units employ voltages as high as 15 kV or 20 kV.

HOW THE OSCILLOSCOPES WORK

HOW OSCILLOSCOPES WORK

Fig. 17. Delayed sweep.

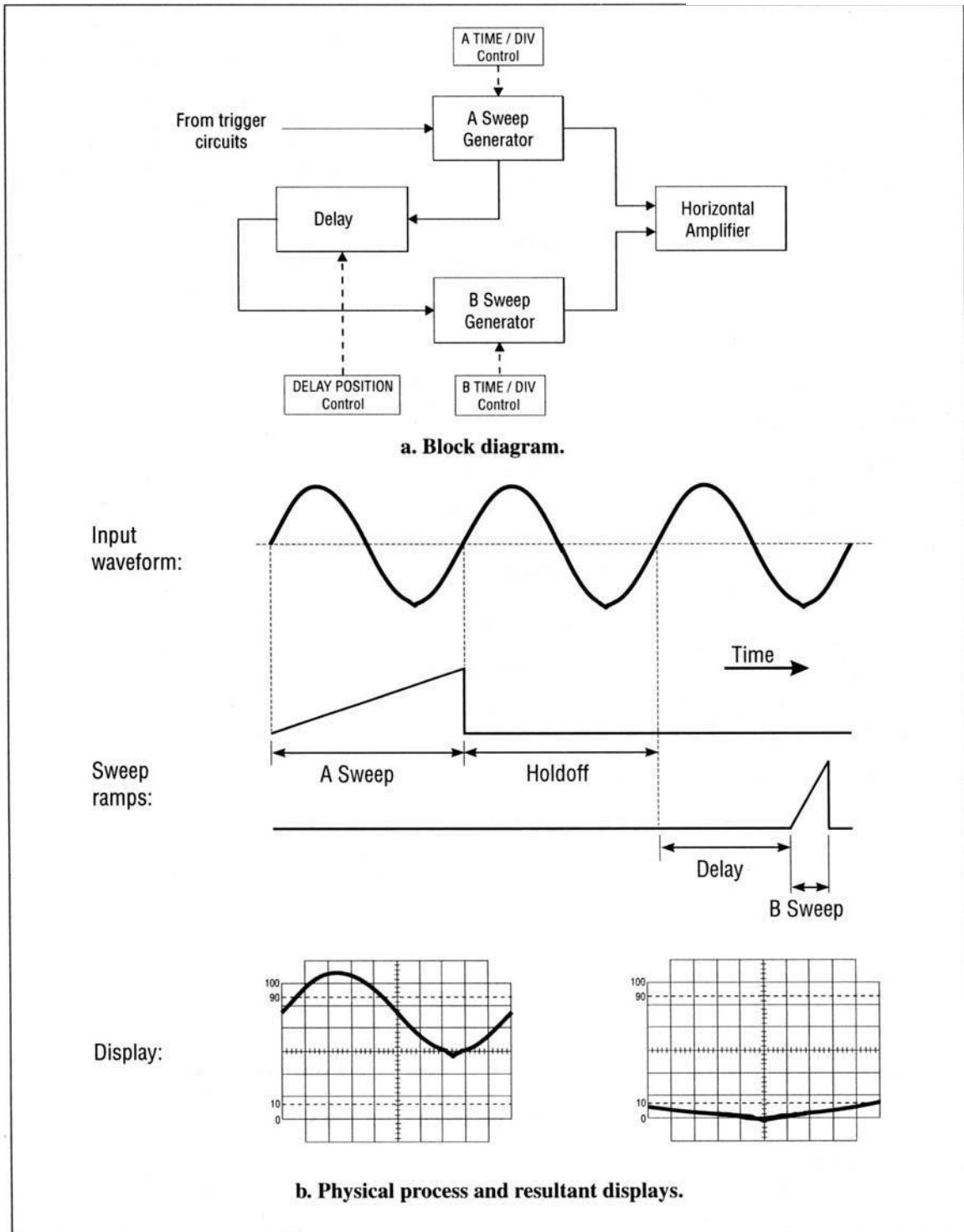

HOW THE OSCILLOSCOPES WORK

DIGITAL STORAGE OSCILLOSCOPES (DSO)

DSO OPERATION

Real-Time Sampling

The block diagram of Fig. 18 is meant to show the inner workings of a DSO in simplified form only. Also, it depicts a single channel; many of the blocks are duplicated in a two-channel DSO. A signal from the vertical preamplifier is fed to a relay or switch, which routes the signal according to whether the scope is in analog or storage mode. In analog mode, it merely sends the signal on to the main vertical amplifier. In storage mode, however, it sends it through the blocks of Fig. 18.

The signal progresses through a signal scaler, which attenuates the signal so that it doesn't exceed the limits of the A/D (analog-to-digital) converter. Optimum scaling equates the A/D limits with the upper and lower edges of the CRT display. Thus, the scaler works in concert with the Volts/Div setting.

The sample-and-hold switch operates under the control of the microprocessor. It may be sampling as quickly as possible, in real-time sampling mode, or it may be sampling at very specific intervals, in equivalent-time sampling (see the next section). The capacitor on its output is critical; it holds the sampled voltage

between samples. The output of the sample-and-hold is fed through a unity buffer to the A/D (analog-to-digital) converter.

The A/D converter is generally a flash type which operates at at least 10 MHz. Its conversions are controlled by the microprocessor in sync with the sample-and-hold switch. It converts the analog voltage applied into a digital quantity eight or twelve bits wide (or more). In the diagram, the wide gray arrows indicate digital buses.

The digital words are stored in a memory which is controlled by the microprocessor, which increments the address counter as each sample is acquired. The memory is generally twice as long as the number of samples required to fill the display. This is because the scope must be able to show not only the data after the trigger event, but as much as a full screen of "pretrigger" data, if specified by the operator. During data acquisition, the microprocessor places the memory in "write" mode via the R/W (read/write) control line.

In order to be useful, the data must be able to be read out from the memory and displayed. The microprocessor reads from the memory with the R/W line set for "read", and applies the

data to a D/A (digital-to-analog) converter, which changes it back to an analog voltage. This is sent to the main vertical amplifier for display. The microprocessor also sends separate binary quantities to another D/A converter which connects to the main horizontal (sweep) amplifier. In this case, the microprocessor controls the X-position of the CRT electron beam as well as its vertical deflection.

As stated previously, this description is one of basics only. All the blocks involved are connected through extensive electronic logic. There may be more than one microprocessor involved, one for data acquisition and another for display.

Equivalent Time Sampling

Equivalent time sampling enables a DSO to digitize waveforms of a higher frequency than its sampling rate, provided that the waveform is repetitive. Instead of taking many samples per cycle, the scope acquires one sample per cycle, or perhaps even one sample per group of cycles, of the input signal. The sampling point is moved in time along the waveform, and after a sufficient number of cycles have occurred, enough samples have been stored to construct a picture of the waveform.

The process is depicted simply in Fig. 19. The

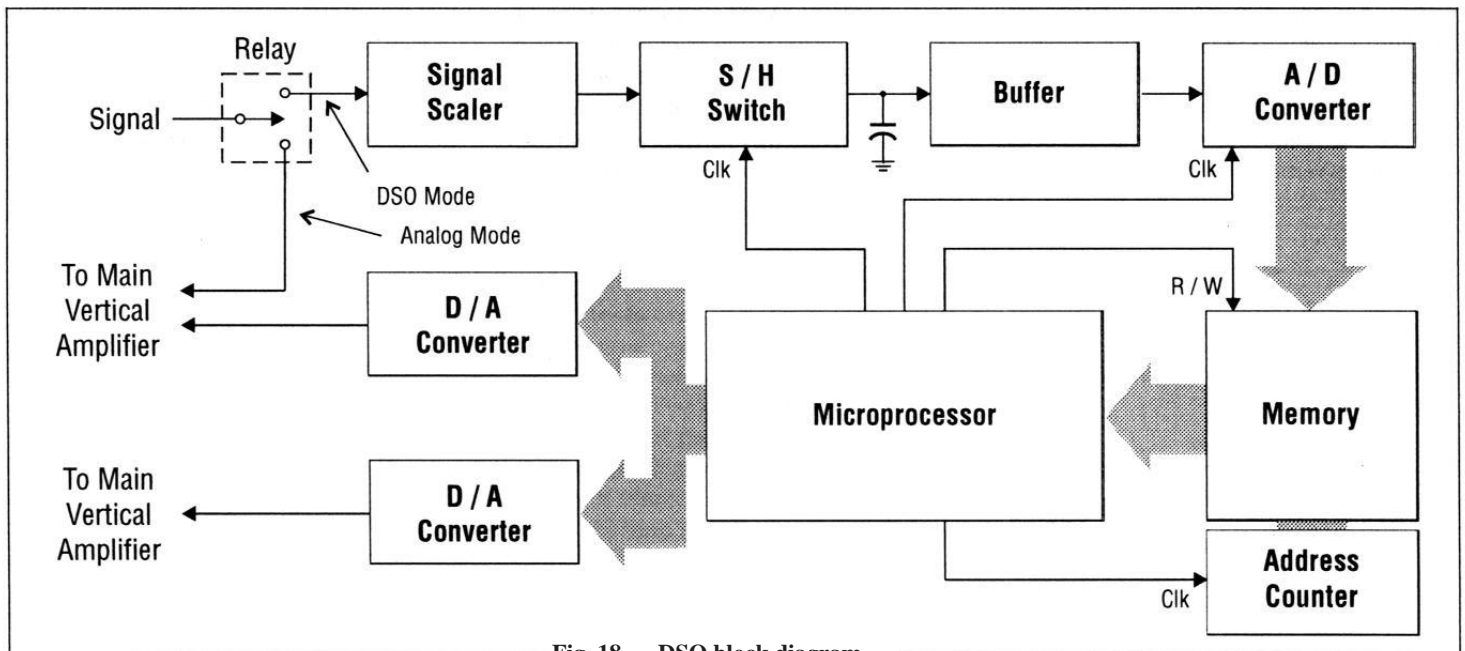

Fig. 18. DSO block diagram

HOW THE OSCILLOSCOPES WORK

sweep ramp from the horizontal circuits is used.

The process is depicted simply in Fig. 19. The sweep ramp from the horizontal circuits is used.

This ramp resets with each trigger event; in this case the trigger is set for the positive zero-crossing. Instead of sampling in a free-run fashion as before, the microprocessor and sample-and-hold circuit now acquire a sample only when the sweep ramp crosses a comparison voltage which is stepping upwards as shown.

This comparison voltage is derived by using a binary counter to count the trigger events, and increment by one for each trigger. The count state is fed to a D/A (digital-to-analog) converter which transforms it into an analog voltage. This is the slowly stepping comparison voltage shown in Fig. 19. The end result is that the intersection point of this voltage and the sweep ramp moves further to the right with each cycle of the input, and so does the sampling point on the input waveform.

This process is actually a controlled use of aliasing, which is a generally undesired result of sampling a waveform too slowly. Aliasing often occurs accidentally in real-time sampling mode, usually due to operator error. The user may not even be aware that the display is totally false, because it appears as a valid waveform. In the case of equivalent-time operation, however, the process is monitored and controlled by the sophisticated logic and software of the DSO and becomes a useful tool.

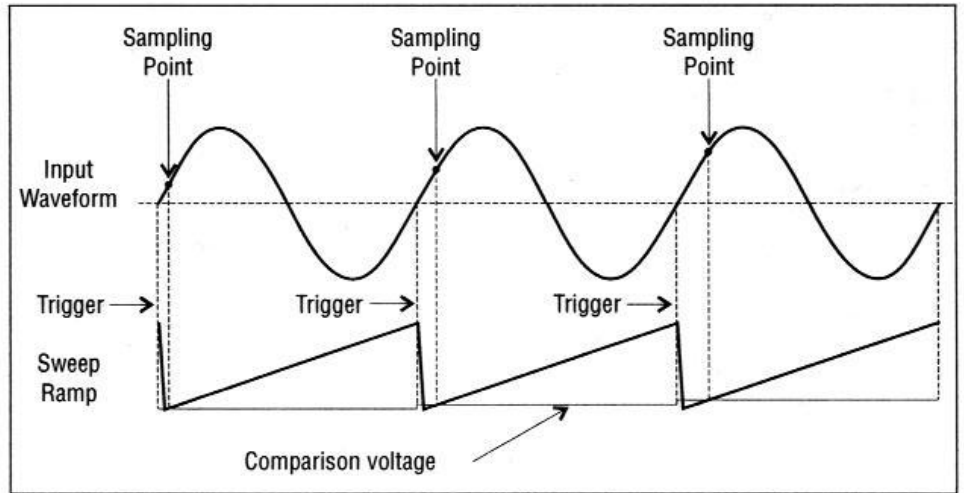

Fig. 19. Equivalent time sampling.

Más información:



VIDEOSISTEMAS
 KLEINFELDSTR. 31
 68165 MANNHEIM
 DEUTSCHLAND – ALEMANIA
 GERMANY

Carrera 34 # 41 – 24
 Tels. 6343328 / 6324139
 Bucaramanga
 COLOMBIA

serviciotecnico@videosistemas.com
www.videosistemas.com